

Dorot Series 100

The direct sealing diaphragm valves were introduced to the world market for the first time by DOROT CONTROL VALVES at 1982. This valve is operated by the pressure of the pipeline and is used for various control applications in water supply, fire fighting, industrial, sewage and irrigation systems.

The only moving component is a reinforced diaphragm, which:

- Drip tight seals the liquid passage in the closed valve
- Allows free passage in the fully open valve with minimal obstruction to the flow line
- Throttles the flow passage in the modulating valve, as dictated by the pressure in the control chamber

The valve can be closed or modulated using the line pressure or an external separate pressure source that is equal or higher than the line pressure.

Dorot S-100 valves are made for easy, inline maintenance, executed also by unskilled personal using basic tools.

There are no shafts, bearings or seals that may corrode and there is no wear and tear by dirty abrasive water or chemicals.

Features and benefits

- Structural simplicity
- Superb design featuring exceptionally low pressure losses at high flow rates
- Can be used for regulating from no-flow to maximal flow with no need for additional throttling devices or by-pass valves
- For natural liquids, sea water and industrial effluents
- A wide selection of materials, coating and diaphragm types
- All valve models fit a wide variety of control applications using Dorot pilot valves



Principle of operation

3-way control system

The main valve is controlled by a manually, electrically or pressure actuated selector that:

- 1 Introduces the upstream pressure or an external pressure source to the valve's control chamber, thus pressing the valve diaphragm from top to a closed position.
- 2 Opens the valve by relieving the pressure from the control chamber and enabling the internal pressure in the line to push the valve diaphragm up and creating an unrestricted, full flow passage.
- 3 Shuts all passages to and from the control chamber, thus keeping the main valve in a fixed position. This position does not exist in devices used for ON/OFF control applications but is necessary in modulating valves.

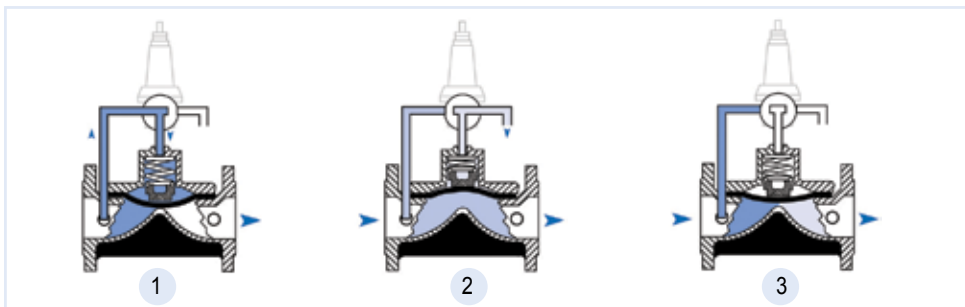

2-way control system

A control system that consist of two restrictions:

- a. A fixed restriction at the upstream side of the control system (nozzle or needle valve)
- b. ON/OFF device (valve, relay or solenoid) or a modulating pilot valve with a larger passage than restriction 'a' that is installed at the downstream side of the control system. The main valve position is affected by the downstream pilot valve 'b' in the following ways:

- 1 When the pilot valve is closed, no water can be vented to the downstream and the main valve is closed by the upstream pressure, introduced into the valve control chamber through the restriction 'a'.
- 2 Opening the valve is enabled when the pilot 'b' is fully open and allows the drainage of pressure in the control chamber to the downstream. At this position the pressure in the control chamber nearly equals that of the downstream.
- 3 Throttling pilot valve 'b' so the flow running through it equals the flow entering through the restriction 'a', keeps a fixed volume of water in the control chamber and the main valve in a fixed position.

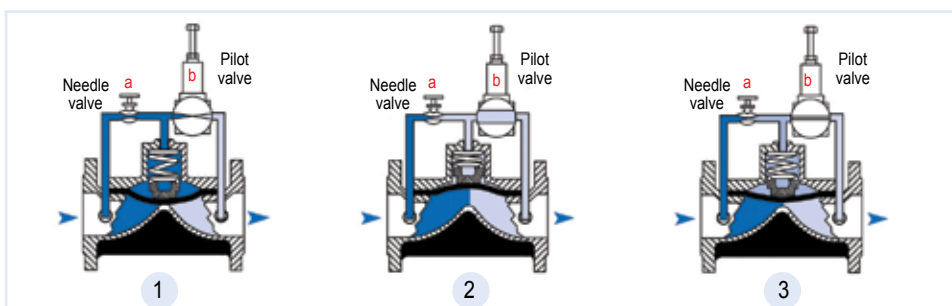

Available Models

Pattern													
Type	44	45	53	47	87	77	82	84	53A	91	67	94	
Connection	Threaded	Threaded	Grooved	Flanged	Flanged	Flanged	Flanged	Threaded	Grooved	Threaded	Flanged	Threaded	
Material	Cast Iron	Bronze	Cast Iron	Cast Iron	Bronze	Ductile Iron	Cast Iron	Cast Iron	Cast Iron	Bronze	Ductile Iron	Ductile Iron	
Max. Pressure												16bar / 250psi	25bar / 360psi
Available Sizes	mm	inch											
	20	3/4	•	•									
	25	1	•	•									
	40	1 1/2	•	•	•				•		•		
	50	2	•	•	•	•	•		•		•	•	
	65	2 1/2	•	•									
	80R	3R	•	•	•				•				
	80	3	•	•	•	•	•	•	•			•	
	100	4			•	•	•	•		•		•	
	150	6			•	•	•	•				•	
	200R	8R				•	•						
	200	8				•	•					•	
	250	10				•	•					•	
	300	12				•	•					•	
	350	14				•	•						
400	16					•					•		
450	18					•					•		
500	20					•					•		
600	24					•					•		

Design Specifications

Materials	Standard	Optional *
Body and Bonnet	Cast Iron, Ductile Iron, Bronze	Cast Steel, Stainless Steel
Diaphragm	Natural Rubber	NBR ,EPDM ,Neoprene
Spring	SST 302	SST 316
Nuts And Bolts	Coated Steel	SST
Coating **	Polyester	Epoxy, Nylon, Rubber

Connections	Standard	Optional *
Flanges	ISO 2084, 2441, 5752	ANSI B16 JIS B22 AS 10
Threads	F-BSP	F-NPT
Control Bores	1/8", 1/4", 1/2" NPT	

* Others Upon Request

** Coating: Complying with European coating standard EN 14901-2014

Non Standard Bonnets

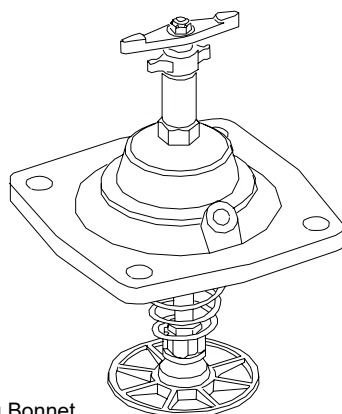

Throttling Bonnet

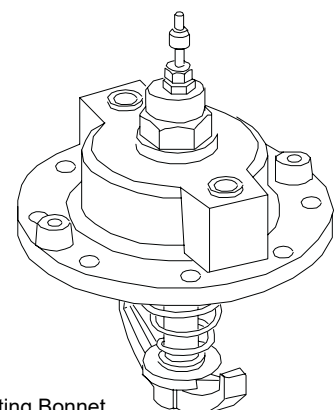

Position Indicating Bonnet

Diaphragm Selection Table*

Diameter		Type	No.	Pressure Range	
mm	inch			mwc	psi
20, 25	3/4", 1"	Standard	18	12-160	17-250
		Low Pressure	85	5-100	7-140
40	1 1/2"	Standard	13	12-160	17-250
		S. Low Pressure	82	5-50	7-70
50, 65, 80R	2", 2 1/2", 3R	Standard	03	15-160	21-250
		EPDM for potable-water use	198	15-160	21-250
		Low Pressure	02	7-100	10-140
		S. Low Pressure	12	4-50	6-70
50HP	2"HP	Extreme	60	20-160	28-250
		High Pressure	69	10-250	15-360
80, 100	3", 4"	Standard	32	12-160	17-250
		EPDM for potable-water use	199	12-160	17-250
		Low Pressure	05	4-100	6-140
		Extreme	61	20-160	28-250
80HP	3"HP	High Pressure	70	10-250	15-360
100HP	4"HP	High Pressure	71	10-250	15-360
150, 200R	6", 8R	Standard	62	20-160	28-250
		EPDM for potable-water use	200	20-160	28-250
		Low Pressure	09	5-100	7-140
		S. Low Pressure	91	2-60	3-85
150HP	6"HP	High Pressure	72	10-250	15-360
		Standard	36	7-160	10-250
200, 300, 350	8", 12", 14"	EPDM for potable-water use	326	7-160	10-250
		Low Pressure	37	2-100	3-140
		Extreme	63	20-160	28-250
		High Pressure	73	10-250	15-360
200HP	8"HP	Standard	40	7-160	10-250
		EPDM for potable-water use	360	7-160	10-250
250	10"	Low Pressure	50	2-50	3-70
		High Pressure	78	10-250	15-360
250HP, 400HP, 500HP, 600HP	10"HP, 16"HP, 20"HP, 24"HP	Low Pressure	92	2-100	3-140

* Standard Diaphragm: Nylon Reinforced Natural Rubber.

Optional diaphragm materials such as NBR, Neoprene, EPDM etc. are available. These include potable-water compatible diaphragms for different pressure-ratings and valve-models other than the ones specified above.

** HP = High Pressure

Pressure Rating

Pressure rating of series 100 valves is body strength, connection standard and diaphragm type.

Pressure rating of valve body of standard models: 16 Bar / 250 psi.

Pressure rating of valve body of high pressure models: 25 Bar / 360 psi.

Connection standard is marked on the identification plate, assembled on the valve body.

Diaphragms operation pressure range is presented at the above table.

Dimensions and Weights

Straight Flow, Threaded Connection

Valve Size		L				H				D		W		Weight			
		Cast Iron		Bronze		Cast Iron		Bronze						Cast Iron		Bronze	
mm	inch	mm	inch	mm	inch	mm	inch	mm	inch	mm	inch	mm	inch	kg	lbs	kg	lbs
20	3/4	115	4.53	112	4.41	43	1.69	43	1.69	20	0.79	68	2.68	1	2.2	1	2.2
25	1	120	4.72	119	4.69	52	2.05	52	2.05	24	0.94	68	2.68	1	2.2	1	2.2
40	1 1/2	170	6.69	149	5.87	93	3.66	86	3.39	33	1.3	93	3.66	2.2	4.9	1.8	4
50	2	188	7.4	184	7.24	115	4.53	101	3.98	42	1.65	112	4.41	3.2	7	2.6	5.7
65	2 1/2	219	8.62	212	8.35	118	4.65	109	4.29	46	1.81	112	4.41	3.6	7.9	3.4	7.5
80R*	3R	225	8.86	221	8.7	126	4.96	116	4.57	54	2.13	112	4.41	4.5	9.9	3.9	8.5
80	3	316	12.44	316	12.44	135	5.31	135	5.31	53	2.09	200	7.87	11	24		

* R = Reduced Port

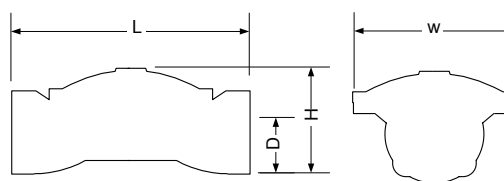

Straight Flow, Grooved Connection (Vic.)

Valve Size		L		H		D		W		Weight	
mm	inch	mm	inch	mm	inch	mm	inch	mm	inch	kg	lbs
40	1.5	177	6.97	81	3.19	26	1.02	93	3.66	1.8	4
50	2	190	7.48	100	3.94	33	1.3	112	4.41	2.6	5.7
80R	3R	201	7.91	120	4.72	47	1.85	112	4.41	3	6.6
80	3	286	11.26	124	4.88	47	1.85	200	7.87	11	24.3
100	4	317	12.48	133	5.24	60	2.36	194	7.64	12	26.4
150	6	392	15.43	250	9.84	82	3.23	300	11.81	31	68.3

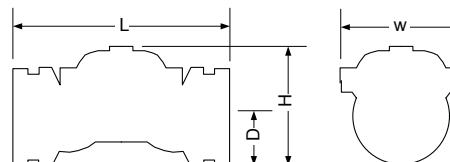

Angle Flow, Grooved Connection (Vic.)

Valve Size		H		D		W		Weight	
mm	inch	mm	inch	mm	inch	mm	inch	kg	lbs
80	3	240	9.45	170	6.69	200	7.87	10.5	23.1
100	4	250	9.84	185	7.28	200	7.87	11.5	25.4

Angle Flow, Threaded Connection

Valve Size		H		D		W		Weight	
mm	inch	mm	inch	mm	inch	mm	inch	kg	lbs
40	1.5	110	4.33	75	2.95	93	3.66	1.7	3.7
50	2	136	5.35	90	3.54	112	4.41	2.4	5.3
80R	3R	165	6.5	114	4.49	112	4.41	3.6	7.9
80	3	239	9.41	145	5.71	200	7.87	10.8	23.8

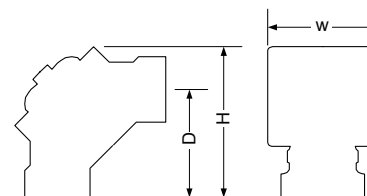

Angle Flow, Flanged Connection

Valve Size		H		D		W		Weight	
mm	inch	mm	inch	mm	inch	mm	inch	kg	lbs
80	3	278	10.9	174	6.85	200	7.87	18	39.7
100	4	300	11.8	185	7.28	230	9.06	21	46.3
150	6	380	15	230	9.06	300	11.8	45	99.2

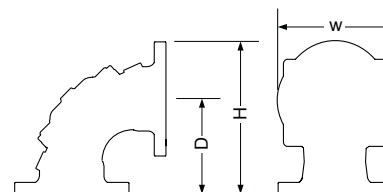

Dimensions and Weights

Straight Flow, Flanged Connection - Standard Models 16 Bar / 250 psi

Valve Size		L		H		D		W		Weight					
mm	inch	mm	inch	mm	inch	mm	inch	mm	inch	Cast Iron		Duct. Iron		Bronze	
mm	inch	mm	inch	mm	inch	mm	inch	mm	inch	kg	lbs	kg	lbs	kg	lbs
40	1 1/2	186	7.32	153	6.02	76.5	3.01	76.5	3.01	5.8	13	6.2	14	6.5	14.3
50	2	200	7.87	166	6.54	85	3.35	166	6.54	7.2	15.8	7.7	17	8	17.6
65	2 1/2	214	8.43	185	7.28	92.5	3.64	185	7.28	10.3	22.7	10.3	22.7		
80R	3R	200	7.87	202	7.95	105	4.13	200	7.87	11	24.3	11.8	26		
80	3	285	11.22	200	7.87	105	4.13	200	7.87	17	37.5	18.2	40.1	19	42
100	4	305	12.01	230	9.06	110	4.33	230	9.06	22	48.5	24	53	24	53
150	6	390	15.35	314	12.36	145	5.71	300	11.8	46	101	49	108	51	112
200R	8R	385	15.16	350	13.78	170	6.69	365	14.4	50	110	54	119		
200	8	460	18.11	400	15.75	170	6.69	365	14.4	80	176	86	190	89	196
250	10	535	21.06	445	17.52	205	8.07	440	17.3	117	258	125	276	131	289
300	12	580	22.83	495	19.49	240	9.45	490	19.3	156	344	167	368	147	324
350	14	580	22.83	495	19.49	270	10.6	530	20.9	182	401	172	379	180	397

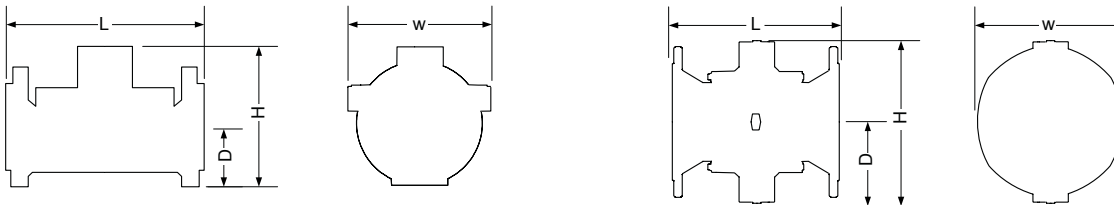

Straight Flow, Flanged Connection - High Pressure Models 25 Bar / 360 psi

Valve Size		L		H		D		W		Weight	
mm	inch	mm	inch	mm	inch	mm	inch	mm	inch	kg	lbs
50	2	228	8.98	169	6.65	85	3.35	175	6.9	10	22
50 TH	2 TH	250	8.98	120	6.65	42	1.65	175	6.9	6	13
65	2 1/2	233	9.18	185	7.28	92.5	3.64	185	7.28	14.5	32
80	3	310	12.2	237	9.33	105	4.13	200	7.87	30	66.1
100	4	356	14.02	263	10.35	120	4.72	260	10.24	38	83.8
150	6	436	17.17	378	14.88	150	5.91	320	12.6	75	165.3
200	8	530	20.87	481	18.94	180	7.09	400	15.75	123	271
250	10	636	25.04	546	21.5	215	8.46	495	19.49	190	419
400	16	709	27.91	830	32.68	310	12.2	830	32.68	433	955
450	18	715	28.15	830	32.68	340	13.39	830	32.68	460	1014
500	20	900	35.43	970	38.19	490	19.29	980	38.58	674	1486
600	24	900	35.43	970	38.19	490	19.29	980	38.58	696	1534

* TH = Threaded

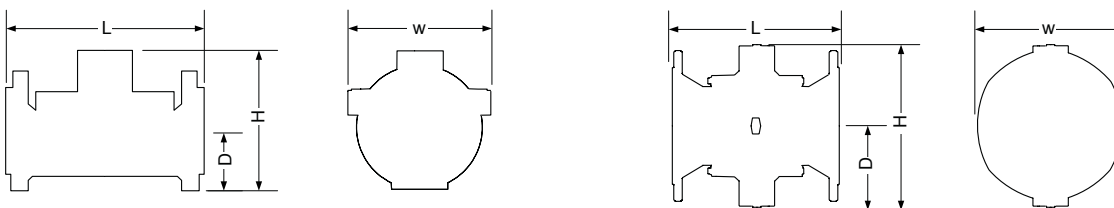

Hydraulic Performance

Valve Size	mm	20	25	40	50	65	80R	80	100	150	200R	200	250	300	350	400	450	500	600
	inch	3/4	1	1 1/2	2	2 1/2	3R	3	4	6	8R	8	10	12	14	16	18	20	24
Max. Flow Continuance	m ³ /hr	6	10	25	40	40	40	100	160	350	350	620	970	1400	1400	2500	2500	3890	5500
	gpm	26.4	44	110	176	176	176	440	700	1540	1540	2730	4268	6160	6160	11000	11000	17116	24200
Max. Flow Intermittent	m ³ /hr	16	27	68	109	109	109	245	273	955	955	1309	2645	3818	3818	6818	6818	10609	10609
	gpm	72	120	300	480	480	480	1080	1200	4200	4200	5760	11640	16800	16800	30000	30000	46680	46680
Minimal Flow	m ³ /hr	< 1																	
	gpm	< 5																	
Kv	m ³ /hr @ 1 bar	17	17	64	95	95	95	170	220	600	670	800	1250	1900	1900	2600	2600	4600	4600
Cv	gpm @ 1 psi	20	20	75	110	110	110	200	260	700	780	930	1460	2220	2220	3030	3030	5370	5370
Kv*	m ³ /hr @ 1 bar	-	-	-	78	-	-	120	200	550	-	800	1300	-	-	2600	2600	4600	4600
Cv*	gpm @ 1 psi	-	-	-	91	-	-	140	230	640	-	930	1520	-	-	3030	3030	5370	5370

* High pressure models

$$\Delta P(\text{Bar}) = \left(\frac{Q[\frac{\text{m}^3}{\text{hr}}]}{Kv} \right)^2 \quad \Delta P(\text{Psi}) = \left(\frac{Q[\text{gpm}]}{Cv} \right)^2$$

Headloss Chart

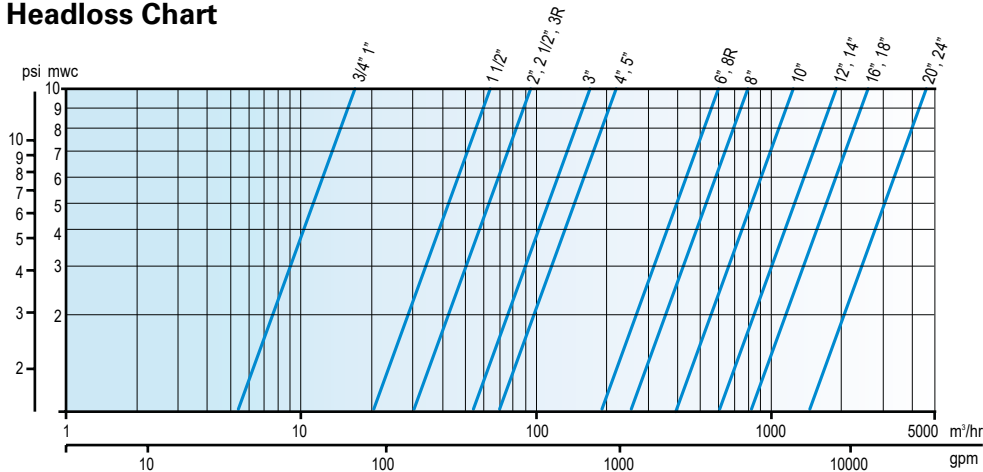

Cavitation Data

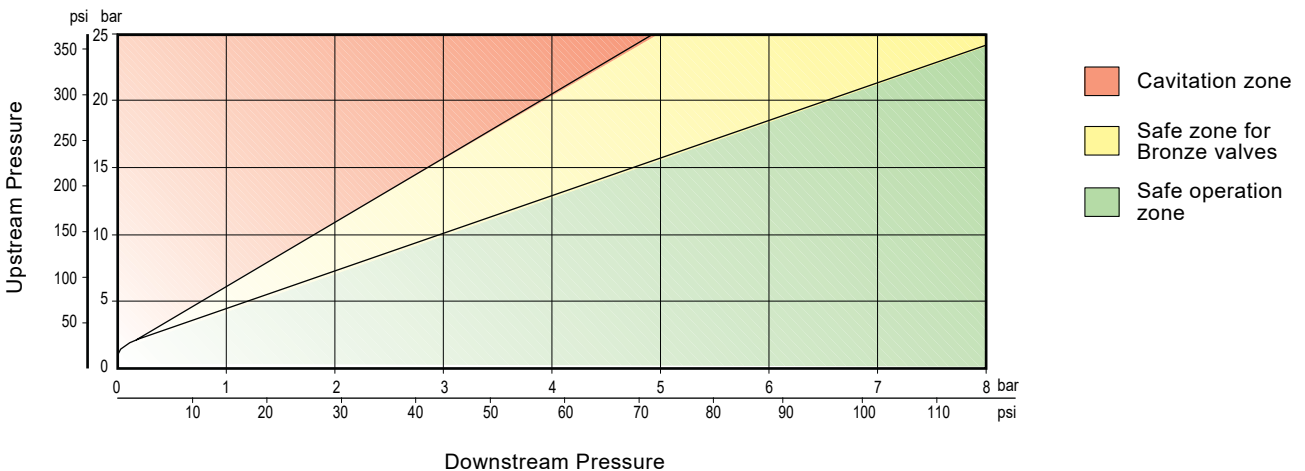

Main Components

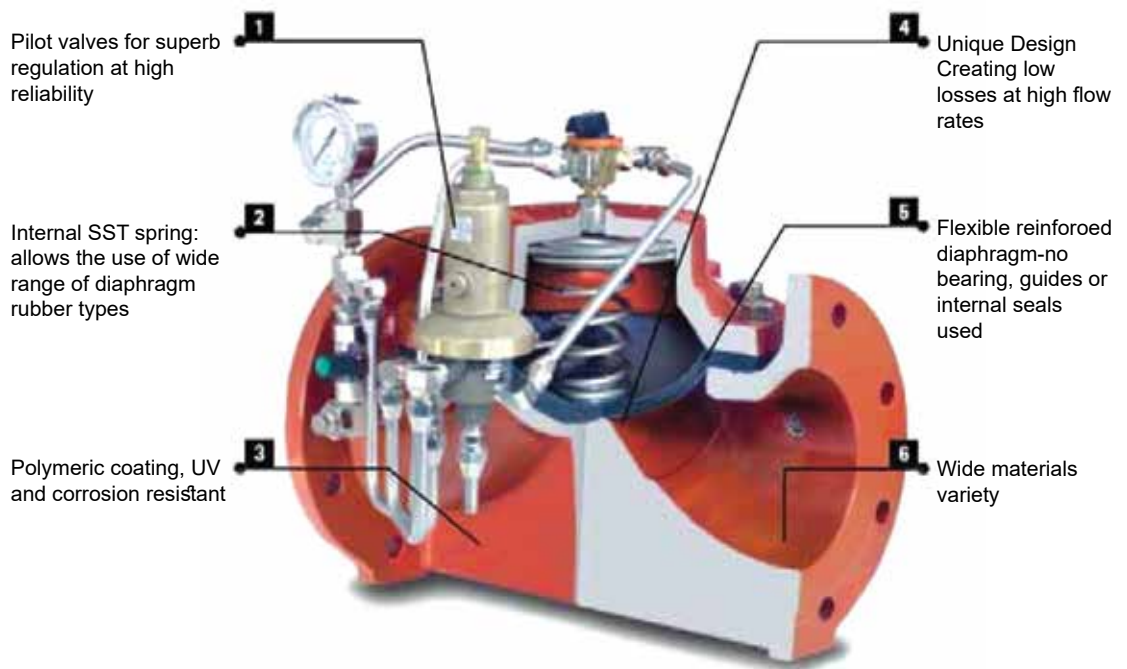

Components

Component No.	Description
1	Body
2	Bonnet
3	Diaphragm
4	Spring
5	Spring Disc
6	Bolt
7	Short Bolt
8	Washer
9	Nut
10	Suspension Ring (Hook)

