

FL Modulating Float Controlled Valve

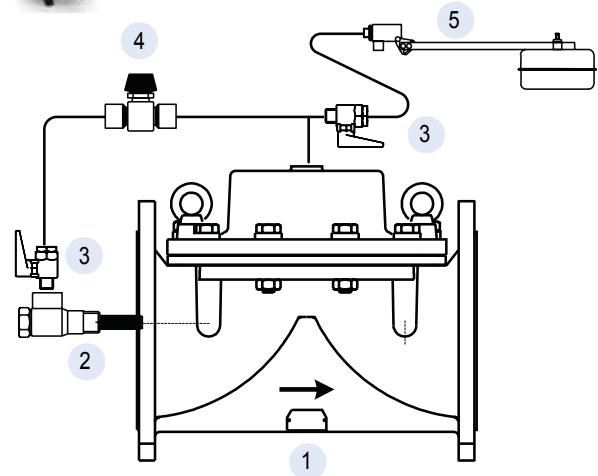

Description

The main valve is controlled by a float valve, located in the tank or reservoir and set at the required maximum water level. The valve maintains the maximum level continuously.

Features

- Accurate and repeatable level control
- Simple and reliable design
- Easy installation and maintenance
- Adjusts the inlet flow to the reservoir's outlet flow

Purchase Specifications

The valve will be hydraulic, direct sealing diaphragm type, which allows inline maintenance. No stem, shaft or guide bearing will be located within the water passage.

The valve will be activated by the line pressure and be operated by a modulating, 2-way float activated pilot valve. The valve and the controls will be a Dorot Series 100 valve or similar in all aspects.

Quick Sizing

- Valve size same as the fill line or one size smaller
- Maximum flow speed for continuous operation 5.5 m/sec (18 ft/sec)

Design Considerations

- The valve should be suited for the maximal flow
- Upstream pressure at closed position should be at least 10m (15psi) higher than the hydrostatic water pressure at the downstream
- Large pressure differentials may cause cavitation damage. Consult Dorot for solutions if such cases are expected
- Prefer use of differential level control in case excessive noise should be avoided (residential areas)

Optional Control System Components:

- 1 Main Valve
- 2 Self-flushing filter
- 3 Cock valve*
- 4 Needle valve
- 5 Modulating float pilot valve

* Optional component

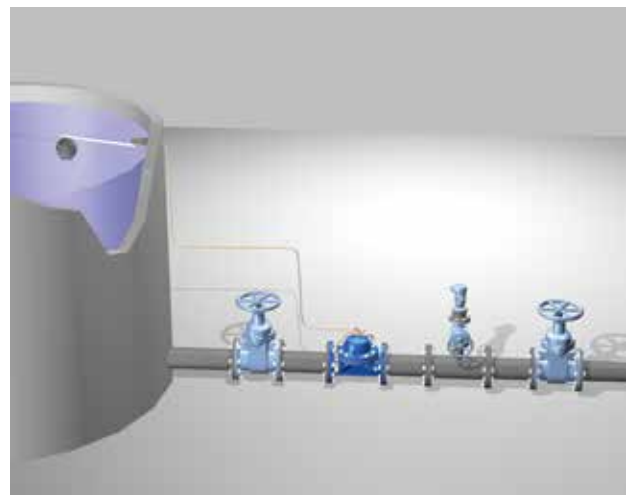

Typical Application

Dorot Modulating Float Controlled valve prevents tank overflow.