

30-NS Two-Stages, Cushioned Closure Check Valve

Principal of operation

The Dorot Series 300 Two Stages Check Valve ('30-NS'), activated by the pressure of the pipeline, The valve eliminate pressure slam of check valves, frequently found in roof-tank filling pumps of high-rise buildings. It opens on pump start, and closes at controlled pace when the pump stops.



S300 Features

- Superb performance:
 - Regulates at a stable mode, regardless of valve-size, down to near-zero flow. Thus, eliminating the need for a special low flow plug-design (such as 'V-port') or a bypass valve.
 - 'Floating', low-friction internal-trim design, guided by unique LPT® device.
- High reliability:
 - All control ports are fitted with SST sleeves for preventing corrosion-blockage.
 - Pre-shaped reinforced diaphragm – for easier assembly and improved longevity.
- Reduced periodic inspection/maintenance labor:
 - The control-trim is fitted with a self-flushing, inline control-filter.
 - Easy in-situ adjustment and maintenance.
- Versatility:
 - A standard and simple single-chamber valve design, provides smooth operation. Conversion to a double chamber is a patented option.

Standard Materials

- Body & Cover – Ductile Iron
Optional – Cast Steel, SST, N.A.B, S.Duplex
- Main Internal – SST (1.5"-6), Coated steel (8"-32")
Optional – Cast Steel, SST, N.A.B, S.Duplex
- Elastomers – EPDM
Optional – NBR, Neoprene, Viton or others
- Coating – Polyester, Epoxy / Optional – Halar and others
- Control trim – Brass, PA / Optional – SST316, Duplex

Purchase Specifications

- The valve will be hydraulic, pilot-operated globe type.
- Face-to-face length dimension meets ISO 5752 Standard.
- The stem will be guided at the top by a replaceable guide bearing and at the bottom by a stainless steel unique LPT® device.
- The valve will regulate any flow within the specified range without the need for a smaller bypass valve or throttling plug.
- All control ports will be corrosion free protected by stainless steel 316 inserts.

Design Considerations

- The valve should be suited for the maximal flow and allowed Headloss.
- Large pressure differentials may cause cavitation damage. Consult Dorot for solutions if such conditions are expected.

Quick Sizing

- Valve sized to be the same as line-size or one nominal-size smaller.
- Maximum recommended flow velocity for continuous operation 5.5 m/sec (18 ft. /sec).

Pressure rating

- Model 30, 30A for medium pressure (PN16 bar / 250 psi)
- Model 31, 31A for high pressure (PN25 bar / 360 psi)

Typical Installation

Typical applications Includes a Two Stages check valve Model 30-NS. The valve eliminate pressure slam of check valves, frequently found in roof-tank filling pumps of high-rise buildings. It opens on pump start, and closes at controlled pace when the pump stops.

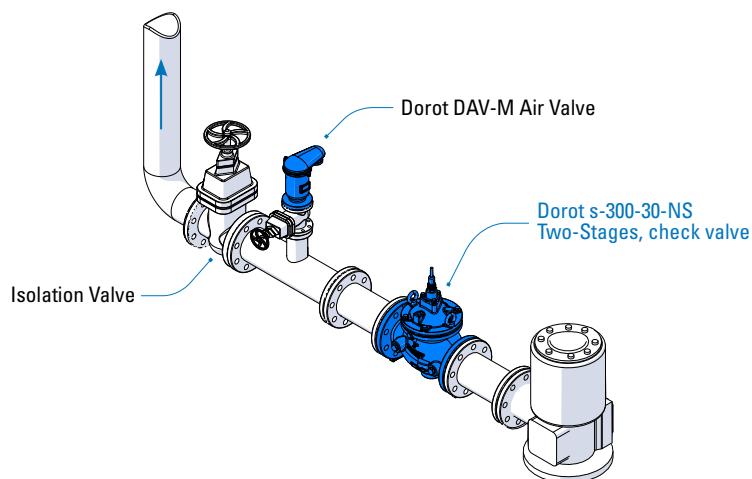

Main Control System Components*

1. Main Valve
2. Ball valve
3. Line filter
4. NS device

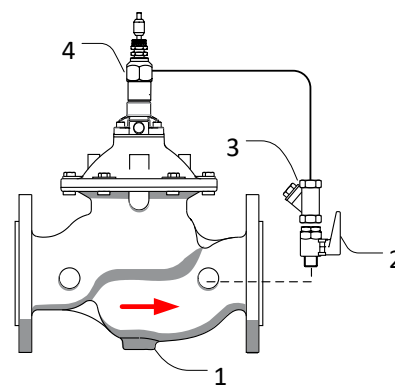

* Indicative drawing