



Direct Pressure Reducing DOROT valves



Applications

The pressure reducing valve maintains, by varying its pressure loss, the outlet pressure at a constant value when inlet pressure or the flow-rate are varying.

Direct- acting PRV's are used:

To maintain a requested pressure constantly below the max. permissible value.

To save water. By controlling the pressure of the outlets, excessive withdrawal of water is prevented, Undetected Leakages are reduced.

In compressed air systems: to keep the constant air pressure regardless of fluctuations in the pressure of the compressors.

To reduce and stabilize the pressure in the outlet of tanks or storage cylinders.

GENERAL

The **DOROT** pressure reducing valves Series DPR, DPR-F are of the balanced seat type. The inlet pressure, when acting on the two openings A and B with the same section, is compensated, and does not exert any force on the pin-plug system when the degree of valve opening changes. Two forces act on the diaphragm: The outlet pressure creates a force that tends to close the plug, and is opposed by the spring mechanical force, that tends to open the plug.

This results in the pressure reducing valve acting like a balanced seat type, where the outlet pressure is almost unaffected by variations in inlet pressure.



DPR

Diaphragm pressure reducing valve with single balanced seat. Ensures min. pressure drops with high flow rates. Downstream pressure set by means of the setting screw (4) and is locked with lock nut (3)

Models	SIZE
DPR-1/2	1/2" 12mm
DPR-3/4	3/4" 20mm
DPR-1	1" 25mm
DPR-11/4	1 1/4" 32mm
DPR-11/2	1 1/2" 40mm
DPR-2	2" 50mm



DPR-P

Like DPR, but with pressure gauge Ø50 for reading gauge downstream pressure

Models	SIZE
DPR-P-1/2	1/2" 15mm
DPR-P-3/4	3/4" 20mm
DPR-P-1	1" 25mm
DPR-P-11/4	1 1/4" 32mm
DPR-P-11/2	1 1/2" 40mm
DPR-P-2	2" 50mm

SIZING

Excessive flow velocity generates too-high pressure drop and noisy performance.

Hence, it is very important that the valve size will be selected properly, considering the maximal flow rate the valve is supposed to regulate.

The diagrams at the right side, allow the selection of the valve size according to the flow velocity, that is caused by the flow rate (bottom axis).

It is recommended to select the valve that operates at flow velocity of 1-2m/s (water systems) and 10-20m/s (air systems).

Flow rate/speed diagram DPR,DPR-P,DPR-N,DPR-N-P,DPR-U

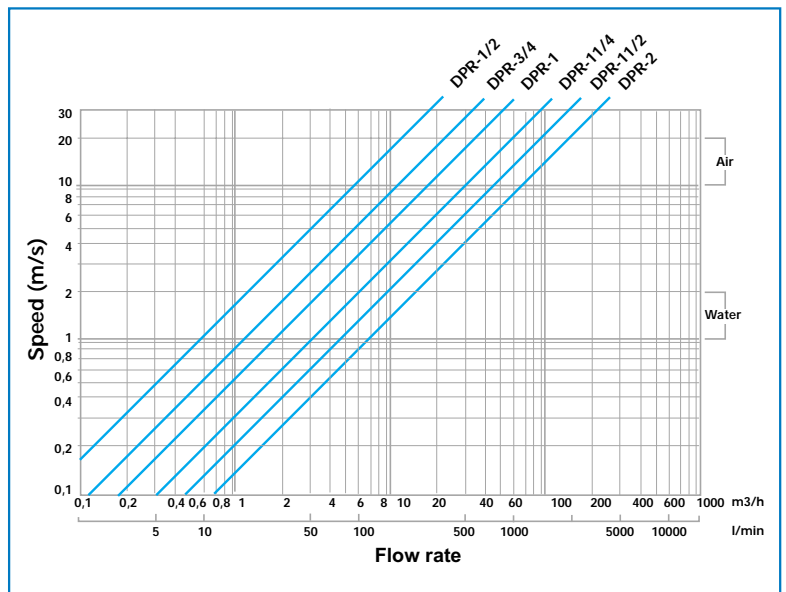

EXAMPLES OF SIZING

Example 1 (cavitation- see next page)

Operating conditions:

Inlet pressure P1 = 14 bar

Outlet pressure P2 = 3 bar

The cavitation diagram indicates that the valve works constantly in the red zone.

To avoid rapid deterioration, two valves can be used, connected in serial configuration:

Upstream valve: pressure difference 14 to 6 bar (green zone)

Downstream valve: pressure difference 6 to 3 bar (green zone).

Example 2 (flow rate-see next page)

Pressure reducing valve DPR/N with:

Inlet pressure (min.) P1 = 8 bar

Outlet pressure P2 = 4 bar

Max. flow rate Q = 50 l/min

The flow rate / speed diagram indicates that a diameter of 20 or 25 can should be used. The pressure drop diagram (next page) indicates the minimal DP:

DPR-3/4 Q = 50 l/min DP = 1.1 bar

DPR-1 Q = 50 l/min DP = 0.68 bar

Flow rate/speed diagram DPR-F

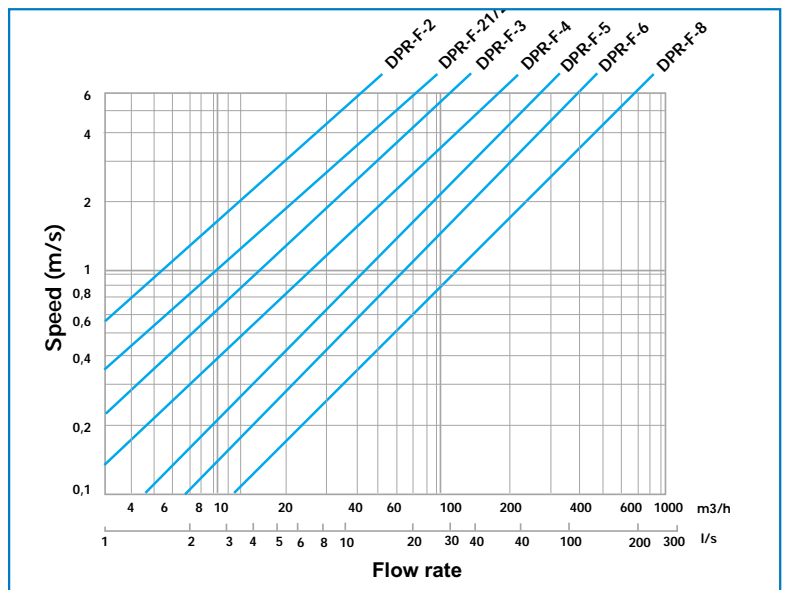

CAVITATION

The cavitation diagram shows three zones of valve operation in relation to the upstream and downstream pressures, namely:

zone C: normal duty, no cavitation

zone B: medium duty, possible cavitation

zone A: heavy duty, the valve cavitates.

Continuous operation in the red cavitation zone causes rapid deterioration of the internal parts. If the pressure reducing valve is to be used in the red zone, please contact DOROT Engineering Department.

APPLICATION

Water, air and neutral (non aggressive) gases.

APPROVALS

- DVGW approval (Arbeitsblatt W 375)
- LGA approval (DPR-N-1/2 to 11/4) according to DIN 4109 class I (noise below 20 dB)
- SVGW approval (W/TPW101).
- TIN approval (Poland)
- CSTB approval (NF P 43-006) (DPR-N-1/2, DPR-N-3/4).
- KTW certification for all materials in contact with water.

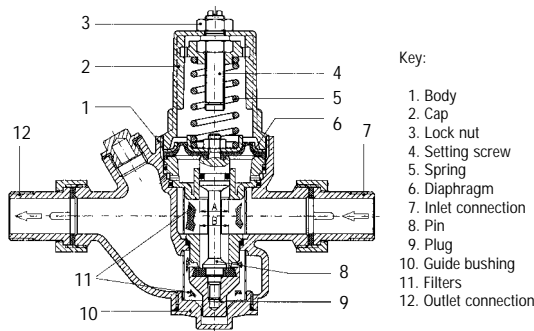

Overall dimensions (mm)

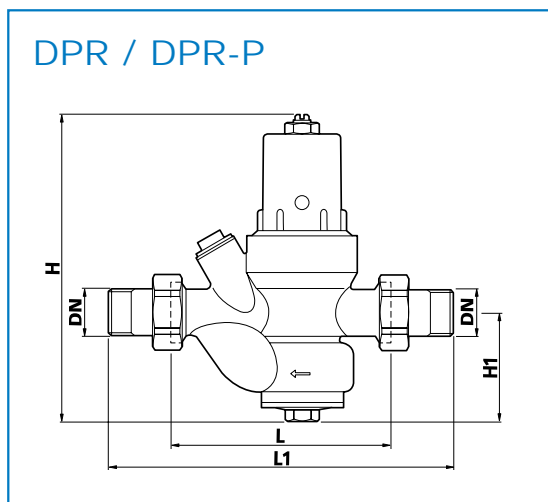

SIZE	L	L1	H	H1
1/2"	97	187	135	48
3/4"	110	215	155	58
1"	120	236	182	66
1.1/4"	140	260	227	75
1.1/2"	160	284	255	82
2"	175	315	262	88

Cavitation diagram

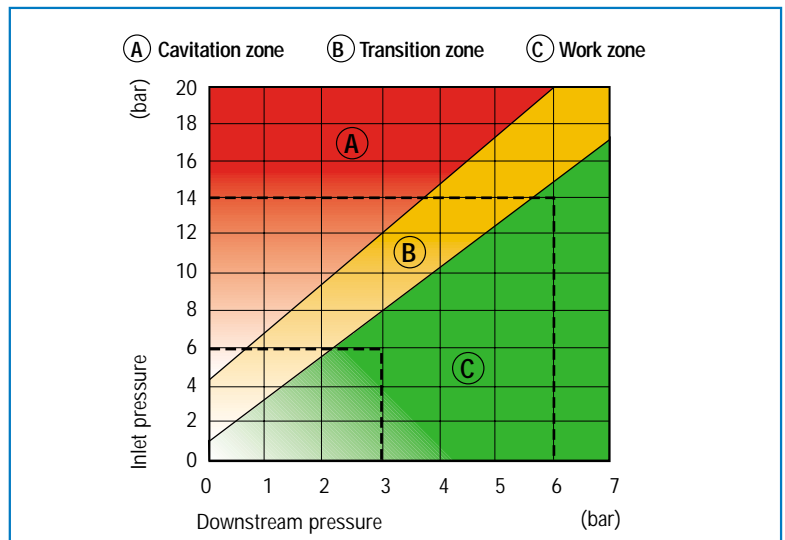

TECHNICAL CHARACTERISTICS

Max. upstream pressure	25 bar
Downstream pressure (outlet)	1.5 to 6 bar
Connections	M to M Union connections
Outlet pressure adjustment (screw 4)	Clockwise rotation increases pressure Counter-clockwise rotation decreases pressure
Outlet pressure gauge (DPR-P only)	Pressure gauge Ø50, scale 0 to 6 bar
Max. operating temperature	30» C

DESIGN FEATURES

Body	Shot-blasted brass OT58
Cap	Shot-blasted brass OT58
Plug	Brass OT58
Inlet / outlet connections	Brass OT58
Diaphragm	NBR with nylon fabric
Seal and O-ring	NBR
Spring	Galvanized steel
Setting screw and lock nut	Brass OT58
Filters	Stainless steel

Flow rate - Pressure drop diagram

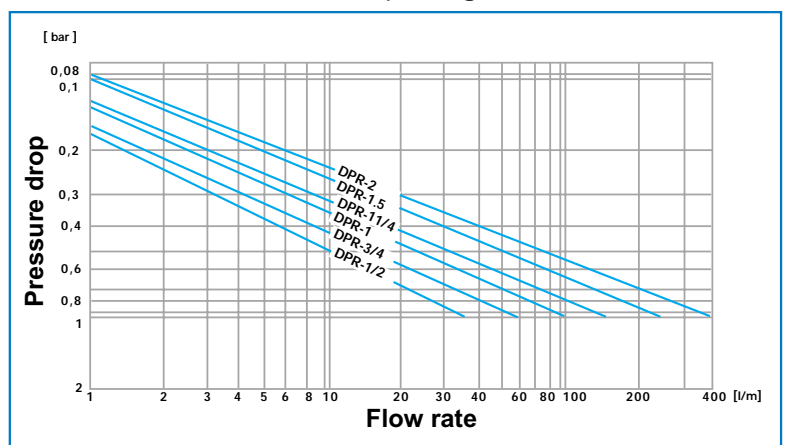

APPLICATION

Water, air and neutral (non aggressive) gases.

APPROVALS

- DVGW approval (Arbeitsblatt W 375)
- LGA approval (DPR-N-1/2 to 11/4) according to DIN 4109 class I (noise below 20 dB)
- CSTB approval (NF P 43-006) (DPR-N-1/2, DPR-N-3/4).
- KTW certification for all materials in contact with water

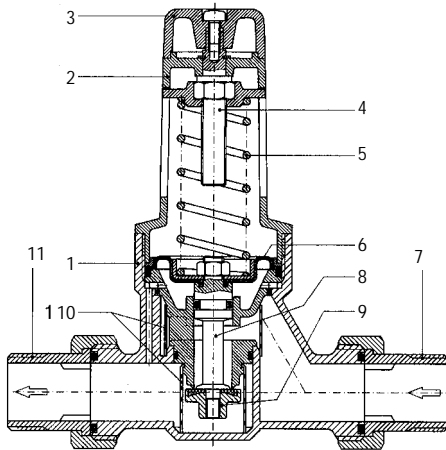

Key:

1. Body
2. Cap
3. Adjusting knob
4. Settling screw
5. Spring
6. Diaphragm
7. Inlet connection
8. Pin
9. Plug
10. Filters
11. Outlet connection

Overall dimensions (mm)

DPR-N / DPR-N-P

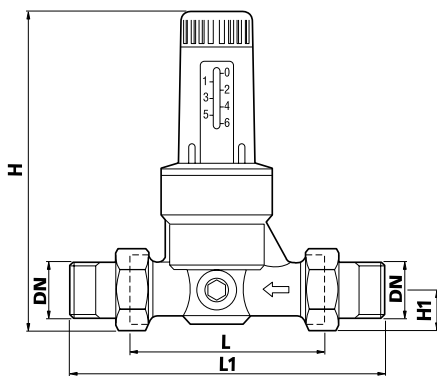

SIZE	L	L1	H	H1
1/2"	97	187	135	48
3/4"	110	215	155	58
1"	120	236	182	66
1.1/4"	140	260	227	75
1.1/2"	160	284	255	82
2"	175	315	262	88



DPR-N

Diaphragm pressure reducing valve with single balanced seat. Ensures min. pressure drop at high flow rates. Downstream pressure set by means of knob (3) with adjustment scale 1 to 6 bar.

Model SIZE

DPR-N-1/2	1/2"	12mm
DPR-N-3/4	3/4"	20mm
DPR-N-1	1"	25mm
DPR-N-1.1/4	1.1/4"	32mm
DPR-N-1.1/2	1.1/2"	40mm
DPR-N-2	2"	50mm



DPR-N-P

Like DPR-N, but with pressure gauge Ø50 for downstream pressure reading.

Model SIZE

DPR-N-P-1/2	1/2"	12mm
DPR-N-P-3/4	3/4"	20mm
DPR-N-P-1	1"	25mm
DPR-N-P-1.1/4	1.1/4"	32mm
DPR-N-P-1.1/2	1.1/2"	40mm
DPR-N-P-2	2"	50mm

DESIGN FEATURES

Body	Shot-blasted brass OT58
Cap	Reinforced plastic
Plug	Brass OT58
Inlet / outlet connections	Brass OT58
Diaphragm	NBR with nylon fabric
Seal and O-ring	NBR
Spring	Galvanized steel
Setting screw	Brass OT58
Filter	Stainless steel

TECHNICAL CHARACTERISTICS

Max. upstream pressure	25 bar
Downstream pressure (outlet)	1.5 to 6 bar
Connections	M to M Union connectors
Outlet pressure adjustment (knob 3)	Clockwise rotation increases pressure Counter-clockwise rotation decreases pressure
Outlet pressure gauge (DPR-N-P only)	Pressure gauge Ø 50, scale 0 to 6 bar
Max. operating temperature	80° C

Flow rate - Pressure drop diagram

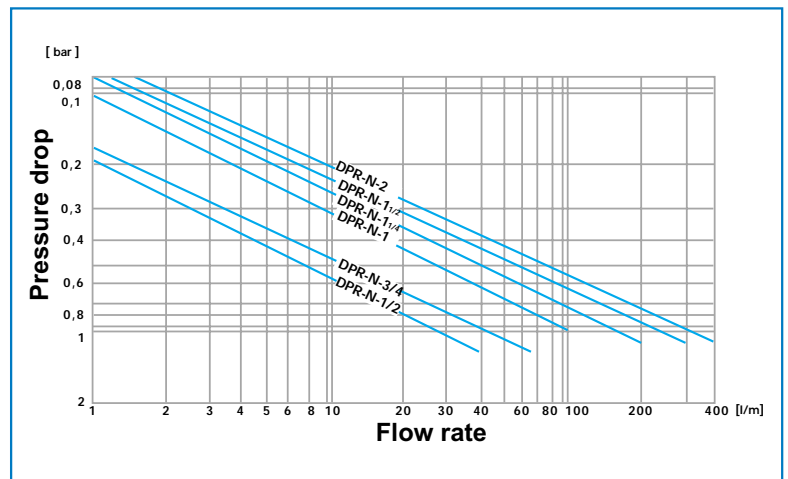

APPLICATION

Water, air and neutral (non aggressive) gases.

APPROVALS

- ASSE, ANSI, CSA, UPC (USA) approvals

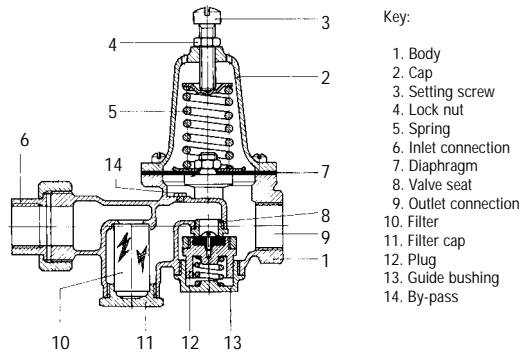

DPR-U

Bronze-body valve

Diaphragm pressure reducing valve, single seated, with spring. Ensures min. pressure drop with high flow rates. Provided with high-capacity filter, having a separate connection for convenient cleaning.

Downstream pressure set by means of screw (3). Fitted with by-pass valve, that allows the release of excessive upstream pressure (generated, for example, by thermal expansion of boiler water) to the downstream side.

Models

SIZE

DPR-U-1/2	1/2"	12mm
DPR-U-3/4	3/4"	20mm
DPR-U-1	1"	25mm
DPR-U-1 1/4	1 1/4"	32mm
DPR-U-1 1/2	1 1/2"	40mm
DPR-U-2	2"	50mm

DESIGN FEATURES

Body	Bronze
Cap	Cast iron
Plug	Stainless steel
Inlet connection	Bronze
Diaphragm	Nordel with nylon fabric
Seal and O-ring	NBR
Spring	Galvanized steel
Setting screw and lock nut	Galvanized steel
Filter	Stainless steel

TECHNICAL CHARACTERISTICS

Max. upstream pressure	20 bar
Downstream pressure (outlet)	Adjustable 1.5 to 5 bar
Upstream connection	M Union connection
Downstream connection	Female thread
Outlet pressure adjustment (screw 3)	Clockwise rotation increases pressure Counter-clockwise rotation decreases pressure
Max. operating temperature	80° C

Special expansion bypass

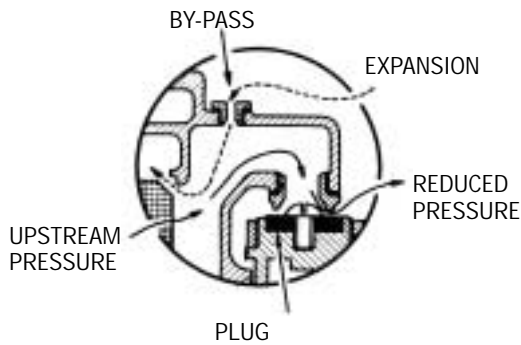

Overall dimensions (mm)

DPR-U

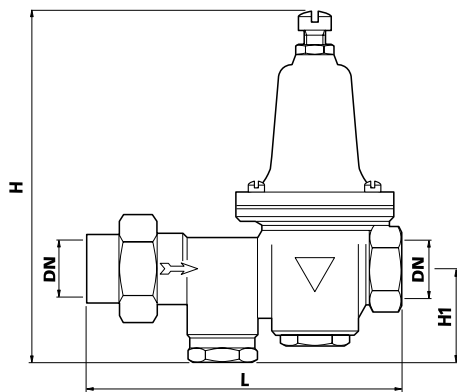

SIZE	L	H	H1
1/2"	146	175	48
3/4"	162	184	48
1"	171	203	51
1.1/4"	203	213	57
1.1/2"	241	248	76
2"	279	311	83

Flow rate - Pressure drop diagram

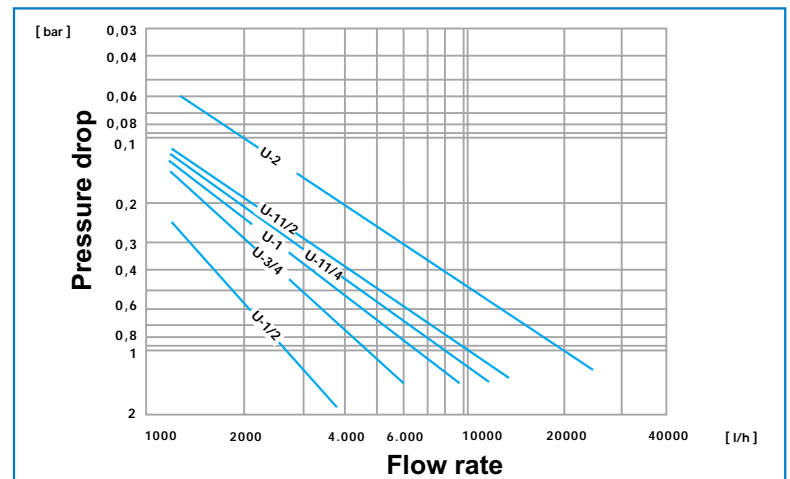

APPLICATION

Water, air and neutral (non aggressive) gases.



DPR-F16-x-[A/B/C]

Flanged pressure reducing valve, single balanced seat and spring. Ensures min. pressure drops with high flow rates. Downstream pressure set by an adjusting bolt. Ductile iron body, epoxy coated.



DPR-F25-x-[A/B/C]

Equal to DPR-F16, but max. inlet pressure 25 bar.



DPR-F40-x-[A/B/C]

Equal to DPR-F16, but max. inlet pressure 40 bar.

PN16 models:

Class A- Outlet setting 1.5-6 bar

DPR-F16-2-A	2"	DN50
DPR-F16-2.5-A	2.5"	DN65
DPR-F16-3-A	3"	DN80
DPR-F16-4-A	4"	DN100
DPR-F16-5-A	5"	DN125
DPR-F16-6-A	6"	DN150
DPR-F16-8-A	8"	DN200

Class B- Outlet setting 2-8 bar

DPR-F16-2-B	2"	DN50
DPR-F16-2.5-B	2.5"	DN65
DPR-F16-3-B	3"	DN80
DPR-F16-4-B	4"	DN100
DPR-F16-5-B	5"	DN125
DPR-F16-6-B	6"	DN150
DPR-F16-8-B	8"	DN200

Class C- Outlet setting 4-12 bar

DPR-F16-2-C	2"	DN50
DPR-F16-2.5-C	2.5"	DN65
DPR-F16-3-C	3"	DN80
DPR-F16-4-C	4"	DN100
DPR-F16-5-C	5"	DN125
DPR-F16-6-C	6"	DN150
DPR-F16-8-C	8"	DN200

PN25 models:

Class A- Outlet setting 1.5-6 bar

DPR-F25-2-A	2"	DN50
DPR-F25-2.5-A	2.5"	DN65
DPR-F25-3-A	3"	DN80
DPR-F25-4-A	4"	DN100
DPR-F25-5-A	5"	DN125
DPR-F25-6-A	6"	DN150
DPR-F25-8-A	8"	DN200

Class B- Outlet setting 2-8 bar

DPR-F25-2-B	2"	DN50
DPR-F25-2.5-B	2.5"	DN65
DPR-F25-3-B	3"	DN80
DPR-F25-4-B	4"	DN100
DPR-F25-5-B	5"	DN125
DPR-F25-6-B	6"	DN150
DPR-F25-8-B	8"	DN200

Class C- Outlet setting 4-12 bar

DPR-F25-2-C	2"	DN50
DPR-F25-2.5-C	2.5"	DN65
DPR-F25-3-C	3"	DN80
DPR-F25-4-C	4"	DN100
DPR-F25-5-C	5"	DN125
DPR-F25-6-C	6"	DN150
DPR-F25-8-C	8"	DN200

PN40 models:

Class A- Outlet setting 1.5-6 bar

DPR-F40-2-A	2"	DN50
DPR-F40-2.5-A	2.5"	DN65
DPR-F40-3-A	3"	DN80
DPR-F40-4-A	4"	DN100
DPR-F40-5-A	5"	DN125
DPR-F40-6-A	6"	DN150

Class B- Outlet setting 2-8 bar

DPR-F40-2-B	2"	DN50
DPR-F40-2.5-B	2.5"	DN65
DPR-F40-3-B	3"	DN80
DPR-F40-4-B	4"	DN100
DPR-F40-5-B	5"	DN125
DPR-F40-6-B	6"	DN150

Class C- Outlet setting 4-12 bar

DPR-F40-2-C	2"	DN50
DPR-F40-2.5-C	2.5"	DN65
DPR-F40-3-C	3"	DN80
DPR-F40-4-C	4"	DN100
DPR-F40-5-C	5"	DN125
DPR-F40-6-C	6"	DN150

DESIGN FEATURES

Body	Ductile iron GS400-15
Cap	Ductile iron GS400-15
Plug (ND 50 to 100) (ND 125 to 200)	Brass Galvanized steel
Seal	NBR
Lip seal	NBR
Seal ring	Bronze
Guide bushings	Bronze
Spring	Faced steel
Setting screw and lock nut	Galvanized steel
Finish	Epoxy resins (blue RAL 5017)

TECHNICAL CHARACTERISTICS

Max. upstream pressure	16 - 25 - 40 bar (ND200 only up to 25 bar)
Downstream pressure (outlet)	1.5 to 6 bar (standard) 2 to 8 bar (optional) 4 to 12 bar (optional)
Outlet pressure adjustment	Clockwise rotation increases pressure Counter-clockwise rotation decreases pressure
Connections	Flanged to UNI2223 (NP16 - 25 - 40)
Pressure gauge connections (upstream and downstream)	G 1/4" ND50 to ND65 G 3/8" ND80 to ND200
Max. operating temperature	80° C

Overall dimensions (mm)

Flow rate - Pressure drop diagram

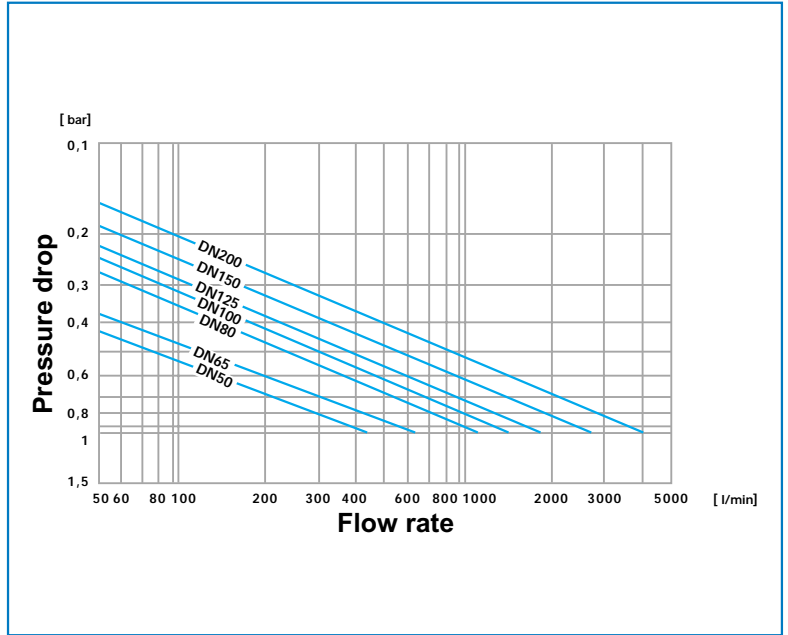
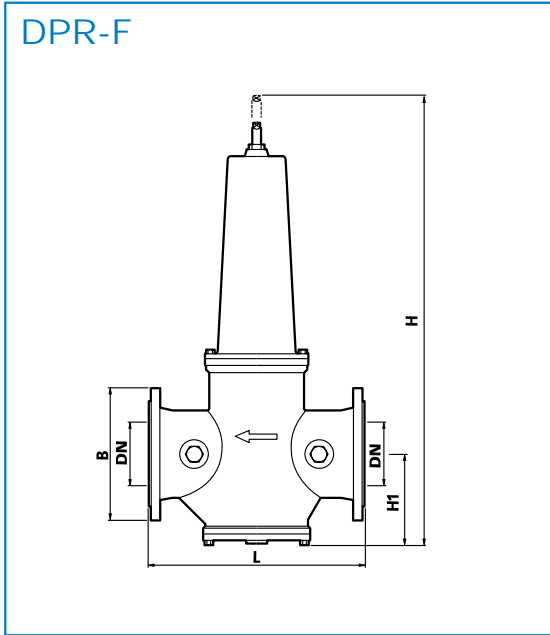

SIZE	L	H	H1	B PN16	B PN25	B PN40
50	230	383	83	165	165	165
65	290	440	90	185	185	185
80	310	490	100	200	200	200
100	350	561	121	220	235	235
125	400	712	152	250	270	270
150	450	839	169	285	300	300
200	550	1684	234	340	360	--

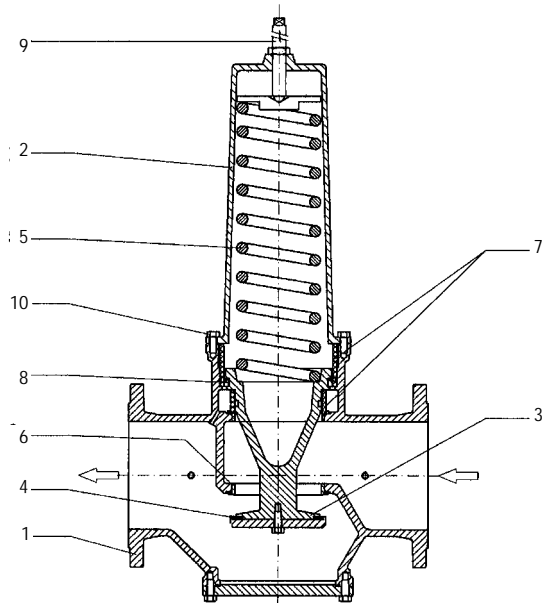

Key:

- 1. Body
- 2. Cap
- 3. Plug
- 4. Seal
- 5. Spring
- 6. Seal ring
- 7. Guide bushings
- 8. Lip seal
- 9. Setting screw
- 10. Cap screws